



PRINT n' GO

FOOTBALL

PRACTICE PLANS

SKILL POSITION DEVELOPMENT

**19 Skill-Building Drills for Quarterbacks,
Running Backs, Receivers and Defensive Backs**



**Includes 5
Printable Practice
Plans**

Copyright Notice - IT IS ILLEGAL TO POST THIS DOCUMENT ONLINE

The material enclosed is copyrighted. You do not have resell rights or giveaway rights to the material provided herein. Only customers that have purchased this material are authorized to view it. If you think you may have an illegally distributed copy of this material, please contact us immediately. Please email support@knowledgespotinc.com to report any illegal distribution.

Copyright © FootballTutorials.com and Knowledge Spot Inc. All rights reserved.

No part of this publication may be reproduced or transmitted in any form or by any means, electronic or mechanical, including photocopying or by information storage and retrieval systems. It is illegal to copy this material and publish it on another web site, news group, forum, etc. even if you include the copyright notice.

Legal Notices

While all attempts have been made to verify information provided in this publication, neither the author nor the publisher assumes any responsibility for errors, omissions or contrary interpretation of the subject matter herein. The publisher wants to stress that the information contained herein may be subject to varying state and/or local laws or regulations. All users are advised to retain competent counsel to determine what state and/or local laws or regulations may apply to the user's particular operation. The purchaser or reader of this publication assumes responsibility for the use of these materials and information. Adherence to all applicable laws and regulations, federal, state and local, governing professional licensing, operation practices, and all other aspects of operation in the US or any other jurisdiction is the sole responsibility of the purchaser or reader. The publisher and author assume no responsibility or liability whatsoever on the behalf of any purchaser or reader of these materials. Any perceived slights of specific people or organizations is unintentional. The author and publisher of this document and their employers make no warranty of any kind in regard to the content of this document, including, but not limited to, any implied warranties of merchantability, or fitness for any particular purpose. The author and publisher of this document and their employers are not liable or responsible to any person or entity for any errors contained in this document, or for any special, incidental, or consequential damage caused or alleged to be caused directly or indirectly by the information contained in this document.

Consult Your Physician

The techniques, ideas, and suggestions in this document are not intended as a substitute for proper medical advice! Consult your physician or health care professional before performing any exercise or exercise technique. Any application of the techniques, ideas, and suggestions in this document is at the reader's sole discretion and risk.

CONTENTS

INTRODUCTION	4
LEVELS OF CONTACT	5
DYNAMIC WARMUP	6
BREAKDOWN PLANT & DRIVE	7
SIDE TO SIDE	8
QUICK FEET DRILL	9
BACKPEDAL SHUFFLE BREAK ON BALL	10
DRILLS	11
CONE PLANT REACTION DRILL	12
CLOCKWORK DRILL	13
SOFTBALL PLANT DRILL	14
STRETCH & BREAK DRILL	15
SIDELINE CATCH DRILL	16
FOOTFIRE DRILL	17
MATCH HIPS	18
DB ZONE BREAK	19
GAME SPEED CATCHES	20
MIRROR STALK BLOCK	21
GAME PREP	22
ULTIMATE FOOTBALL	23
3 ON 3 PASSING	24
MAN PRESS DRILL	25
TEAM PLAY REVIEW	26
PRACTICE PLANS	27
60 MINUTE SKILL WORK PRACTICE	28
60 MINUTE SKILL WORK PRACTICE	29
90 MINUTE SKILL WORK PRACTICE	30
90 MINUTE SKILL WORK PRACTICE	31
120 MINUTE SKILL WORK PRACTICE	32



INTRODUCTION

LEVELS OF CONTACT

At the top of each page, you will notice one of the 5 icons below. They each designate a different level of contact for that specific drill.

By designating each drill a specific level of contact, coaches are able to plan practices in advance and ensure players spend the right amount of time in pads.

USA Football recommends no more than 30 minutes per practice of full contact, and no more than 90 minutes per week during the season, while during the preseason 120 minutes per week is acceptable.



Air. Intensity: 1

Drill is run unopposed and without contact



Bag. Intensity: 2

Drill is run against a bag or soft-contact surface

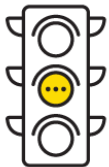

Control. Intensity: 3

Drill is run at an assigned speed until the moment of contact with one player as the predetermined winner. Contact is above the waist, and players stay on their feet



Thud. Intensity: 4

Drill is run at competitive speed through the moment of contact. There is no predetermined winner. Contact is above the waist, players stay on their feet, and a quick whistle ends the drill



Live. Intensity: 4

Drill is run in game-like conditions. This is the only time players are taken to the ground.

DYNAMIC WARMUP

Complete each exercise for 2 sets of 10-20 yards



High Knee Run



Buttkicker Run



Frankenstein Walk



Walking Lunge & Twist



Walking Knee Hug



Straight Leg Run

BREAKDOWN PLANT & DRIVE



Contact Level

PURPOSE:

To get players loose and work on their ability to accelerate, decelerate, and change direction under control.

SETUP:

Setup 6 cones – form a square with the first 4, and then place two more in a line coming out of the circle, as seen in the illustration below. Players will form a line at the first cone.

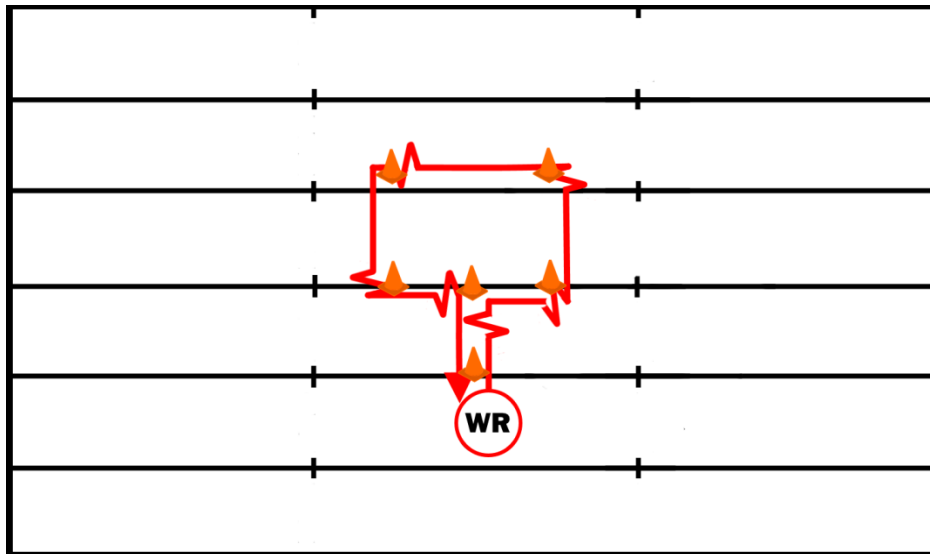

INSTRUCTIONS:

1. The first player in line will begin by sprinting to the first tire to the 2nd, and then reach down with his inside hand to touch the side of the tire as he runs a full circle around that tire.
2. He will then continue forward to the next tire, running his hand alongside it as well as he sprints around.

COACH'S CORNER

- Make sure players aren't letting their feet drift out from underneath them – this will throw off their center of gravity and increase the likelihood of a slip or stumble.
- Players should have a ball in the opposite hand as the one touching the tire as they run.

SIDE TO SIDE



Contact Level

PURPOSE:

To get players loose and comfortable catching the ball on the move.

SETUP:

Have the players separate and form two lines about 5 yards apart, facing each other at the goal line, one with footballs, and one without.

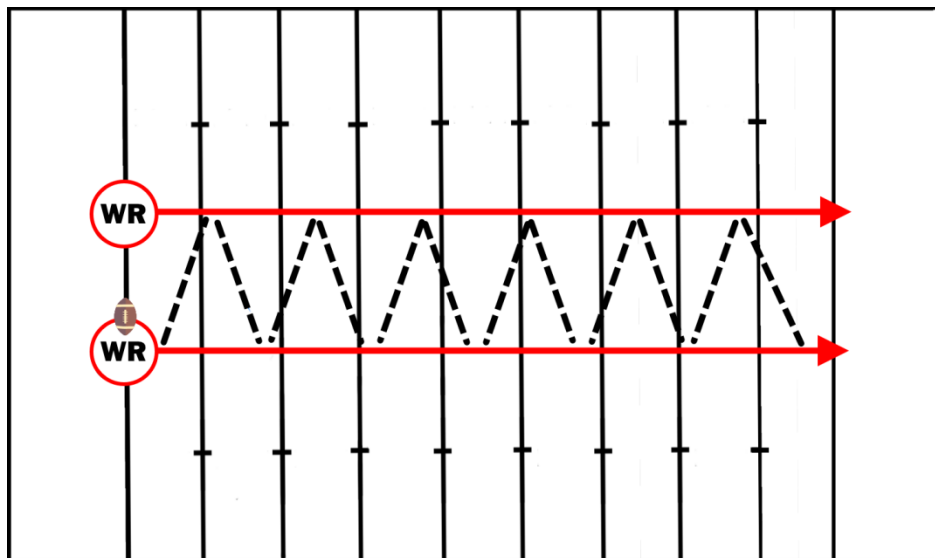

INSTRUCTIONS:

1. The first two players in each line will shuffle sideways while passing the ball back and forth, running the length of the field.
2. Once the players in front of them have reached the 20 yard line, the next pair will take off.

COACH'S CORNER

- You can have players carioca instead of a side shuffle to add an extra layer of difficulty.
- Every time a player drops the ball, they must go to the back of the line and restart from the beginning
- You can also throw in an extra 5 push up penalty for drops!

QUICK FEET DRILL



Contact Level

PURPOSE:

To get players loose while working on agility and balance.

SETUP:

Setup 6 agility bags about 2-3 yards apart. Have the players form a line 5 yards from one end, and place a cone 5 yards from the end of the last bag. Each player will have a ball in hand.

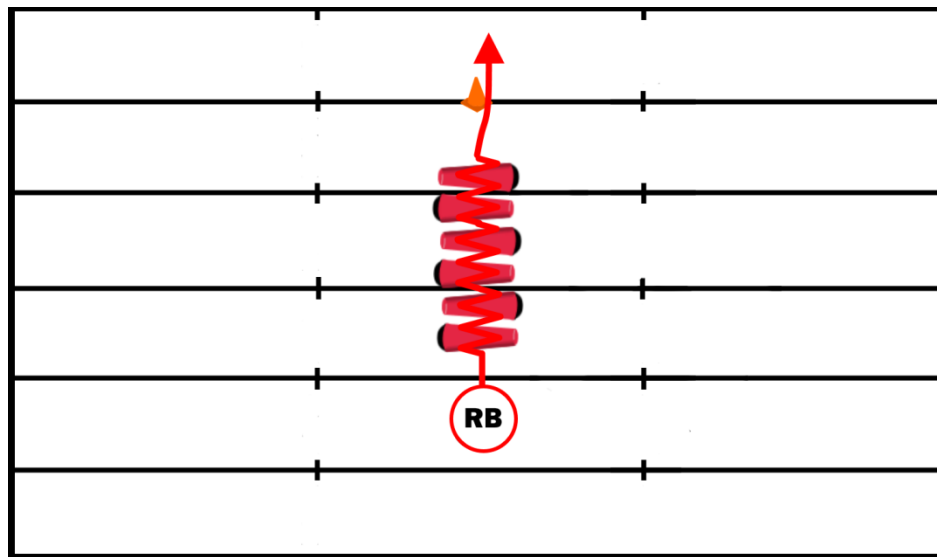

INSTRUCTIONS:

1. One by one, players will step up and run through the bags, exploding for the last 5 yards past the cone.

COACH'S CORNER

- While the focus here is on agility, don't forget to stress ball security!

BACKPEDAL SHUFFLE BREAK ON BALL



Contact Level

PURPOSE:

To work on footwork, agility and develop ballhawking instincts.

SETUP:

The defensive backs will form a line 5 yards in front of the coach, who will have a football in hand.

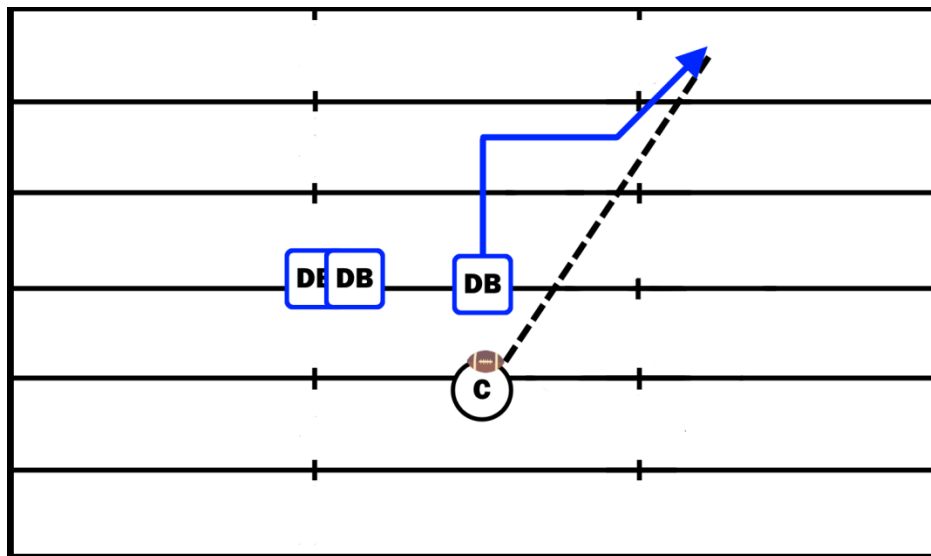

INSTRUCTIONS:

1. The DB will keep his eyes on the ball in the coach's hand.
2. The coach will lead the DB with the ball, with first movement signaling a snap and for the DB to get into a backpedal.
3. Next, the coach will point to the right, and the DB will plant and shuffle to his left.
4. Lastly, the coach will throw a pass at a 45 degree angle over the head of the DB – as soon as the coach begins his throwing motion, the DB will open their hips and break on the ball, intercepting the ball.

COACH'S CORNER

- Make sure to alternate directions and ball placement to keep players on their toes.
- Make sure players stay low and keep their eyes up on the coach.



DRILLS

CONE PLANT REACTION DRILL



Contact Level

PURPOSE:

To teach and reinforce the proper technique when backpedaling and changing direction.

SETUP:

Set out two pairs of cones about 10 yards apart, with 2 more pairs 5 and 10 yards behind the first. Players will form two line, with the first two players stepping out to the first two cones. You'll also need a coach in front of the players with a ball.

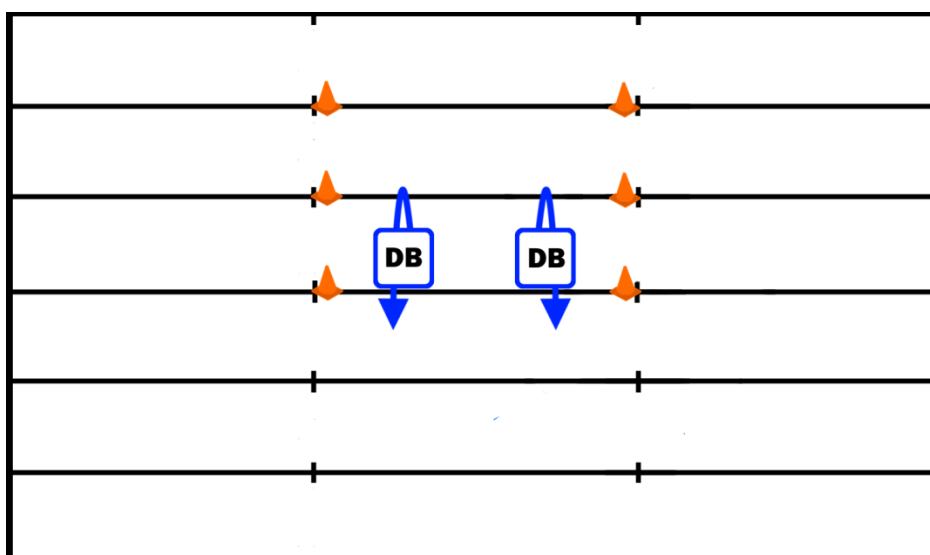

INSTRUCTIONS:

1. The coach will use the ball as a signal for the defensive players. On his first signal the defensive players will begin backpedaling.
2. Once they reach the second set of cones, the coach will signal for the defenders to break forward to the first cone again.
3. Once they reach the first cone, the coach will signal again for them to backpedal, leading them all the way to the cones at the back.
4. The coach will then signal one final time, sending the players forward and through

COACH'S CORNER

- Players should not be looking behind – all their focus should be on the coach and the ball.

CLOCKWORK DRILL



Contact Level

PURPOSE:

To work on catching the ball away from the body, isolating the hands.

SETUP:

Have players pair off and spread out, standing about 10 yards apart. Each pair will need a football.



INSTRUCTIONS:

1. One at a time, players will throw a series of passes "around the clock".
2. This means they will begin with a pass at 12 o'clock, then work their way all the way around, throwing 5-6 passes.
3. After a pair has gone around the clock once, have the pair switch roles and continue.

COACH'S CORNER

- You can also have players stand perpendicular to the passer, and work on making catchers around the clock from a sideways position.

SOFTBALL PLANT DRILL



Contact Level

PURPOSE:

To teach players the proper technique when it comes to sinking the hips to change direction.

SETUP:

Have the players form a line, and place a cone 10 yards downfield in front of them.

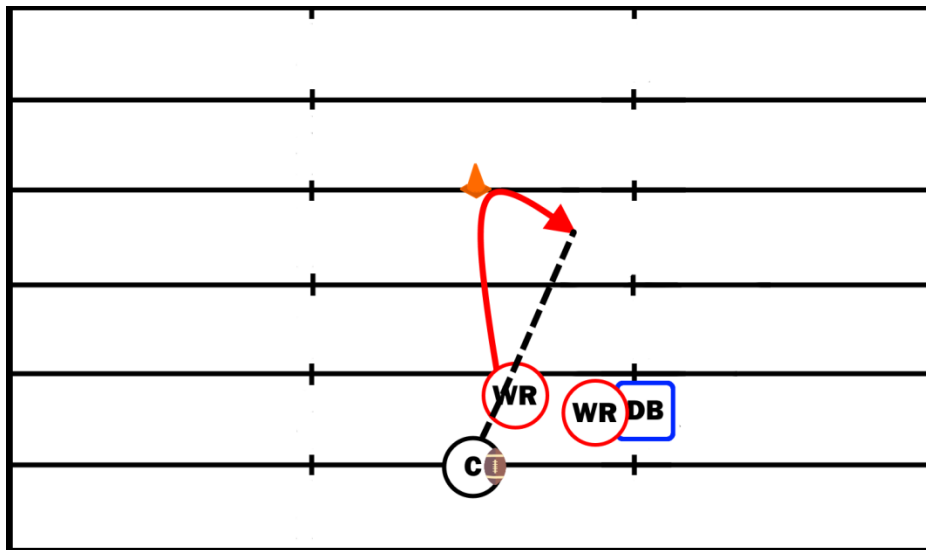

INSTRUCTIONS:

1. Starting from an athletic stance, the player will sprint downfield towards the cone.
2. As they approach the cone, they will chop their feet, sink their hips, plant, and touch the cone with their inside hand.
3. They will then push off, and explode for 5 yards at about a 45 degree angle back towards the line of scrimmage.

COACH'S CORNER

- To add an extra layer to the drill, have either a coach or a quarterback stand 5 yards behind the line of players and throw a pass to the player after he has made his plant and cut back to the ball.

STRETCH & BREAK DRILL



Intermediate



Contact Level

PURPOSE:

To work on a defensive back's awareness, recognition, and ballhawking instincts.

SETUP:

You'll need a passer on the LOS, and a WR on either side of him, about 10 yards away. You'll also need a defensive back, 10-15 yards off the LOS, in line with the passer.

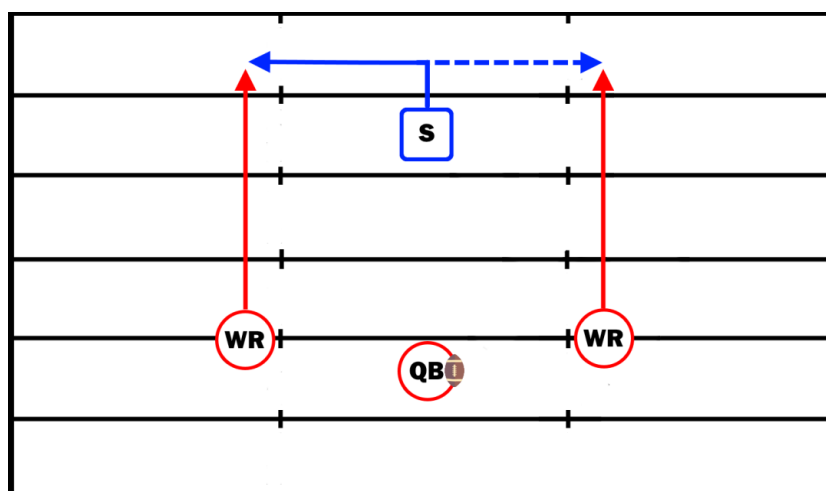

INSTRUCTIONS:

1. The passer will snap the ball, with both WRs taking off downfield, running streaks. The DB will begin to backpedal, or 'stretch', keeping both receivers in front of him.
2. After they've run about 5-10 yards, the QB will rotate his shoulders and eyes onto one receiver.
3. The DB must read the passer's eyes, plant, drive, and break on the ball, intercepting and accelerating forward upfield another 10 yards.

COACH'S CORNER

- Begin with the WRs fairly close together, but as DB's progress, move them further and further apart – same with the QB. At first, you'll want him to give away his intended WR pretty deliberately, but later on, the passer can more closely simulate a game situation with his passing motion.

SIDELINE CATCH DRILL



PURPOSE:

To get players comfortable making the catch near the sideline and coming down inbounds.

SETUP:

Have the players line up and spread out on the goal line.

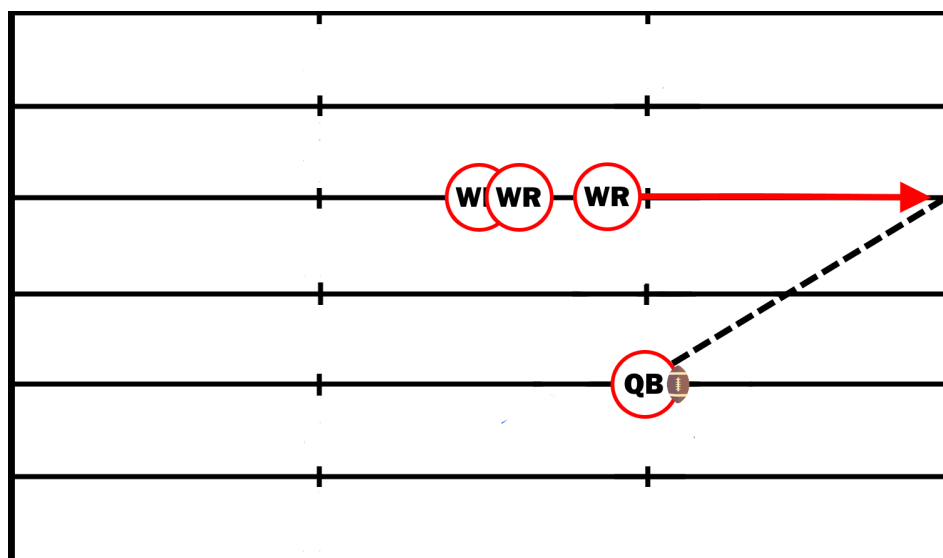

INSTRUCTIONS:

1. On the coach's signal, the players will begin running for the 40 yard line.
2. Players will begin at about 70%, slowly building up their speed and intensity, until they are going full speed for the last 10 yards.

COACH'S CORNER

- Make it clear to players that this drill is not a race. The focus is on warming up and running with control and pace.

FOOTFIRE DRILL



Contact Level

PURPOSE:

To work on decelerating into cuts, footwork, and blocking in the run game.

SETUP:

Have players pair off with teammates of similar strength and size. Each pair will need a blocking shield. The DB will stand 5 yards in front of the receiver.

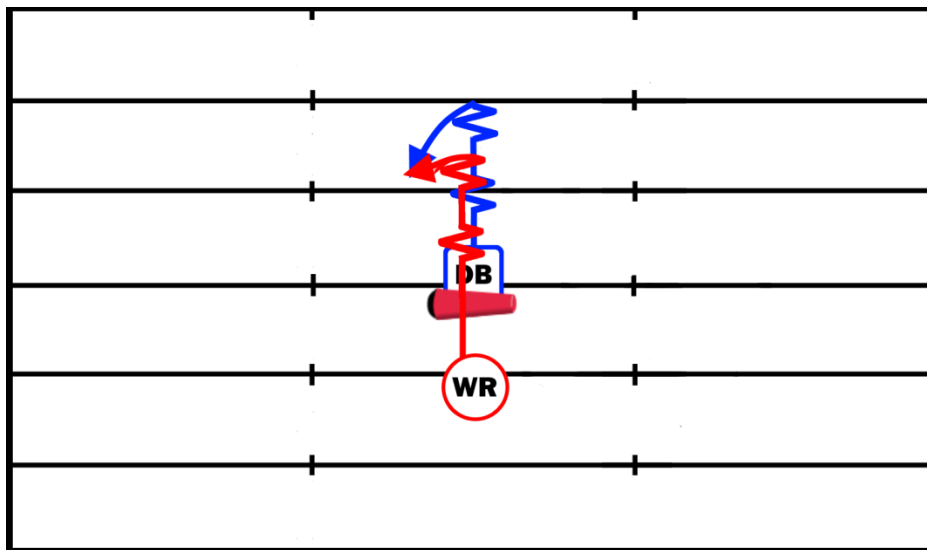

INSTRUCTIONS:

1. On the coach's signal, the WR will come out of his stance and begin running down field.
2. The DB will backpedal with the receiver and maintain a 3 yard cushion as they move downfield.
3. On the coach's whistle, the DB will break down and attempt to get past the WR.
4. The WR will chop his feet down, gain his balance, and get into a fit position, mirroring the DB and blocking him.

COACH'S CORNER

- WR blocking isn't about pancakes – the key is to stay engaged, get a good fit position, and stay engaged as they chop their feet and drive the DB back.

MATCH HIPS



Contact Level

PURPOSE:

To teach defensive players how to sink their hips and react to a WR.

SETUP:

Have players pair off with players of similar speed and size, and have the defensive player line up 6 yards off the line of scrimmage with both players in stance.

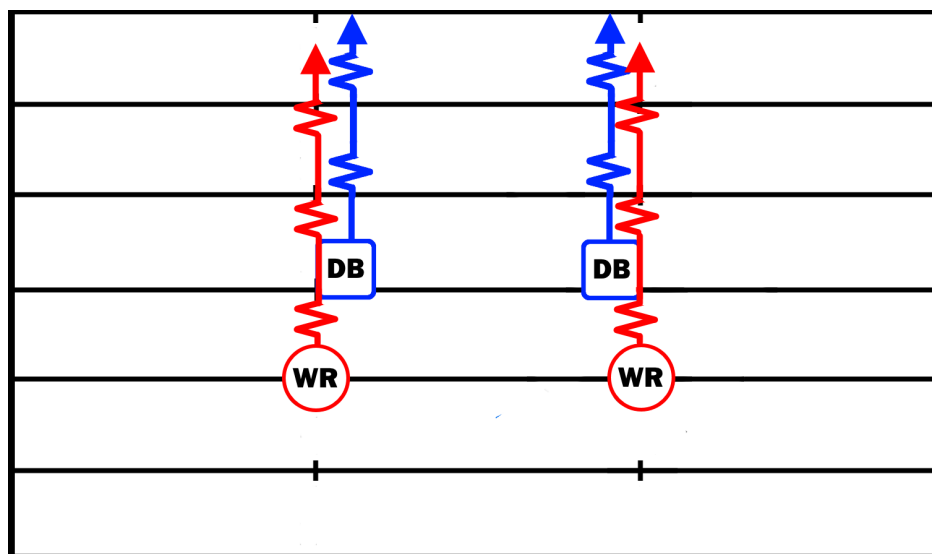

INSTRUCTIONS:

1. On the coach's signal, the WR will fire off the line towards the defender, with the DB backpedaling along with him.
2. The WR will breakdown, sink his hips and chop his feet every few yards.
3. The DB will react and sink his hips along with the WR.
4. Once they've gone 20 yards down field, have the players switch positions and repeat the drill coming back down the other way.

COACH'S CORNER

- The WR should also occasionally break in or outside, forcing the DB to stay alert and react.

DB ZONE BREAK



Contact Level

PURPOSE:

To teach defensive backs how to read the quarterback's eyes and drive on the ball when in zone coverage.

SETUP:

You'll need two WRs and a passer, as well as a line of DBs. The first DB in line still stands 15 yards in front of the QB, with the wide receiver 5-10 yards apart 10 yards downfield.

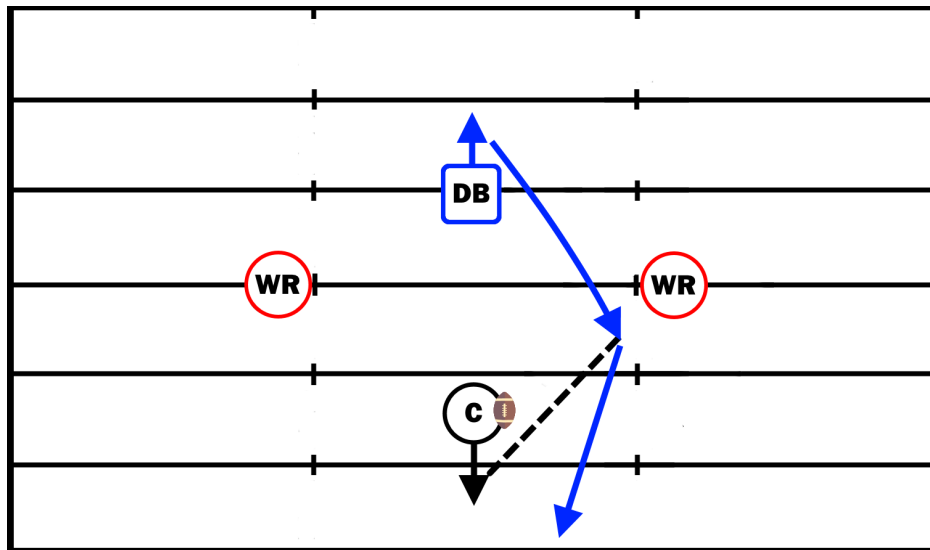

INSTRUCTIONS:

1. The QB will take his drop, and the DB will begin to backpedal.
2. When the QB plants, he will turn his shoulders and eyes towards one of the WRs.
3. The DB must read the QB, plant, and drive on the ball as the QB releases the pass.
4. The DB must then intercept the ball and accelerate upfield.

COACH'S CORNER

- There are two keys to making an ideal break on the ball: the eyes and the feet.
- The DB should have his eyes on his QB on the backpedal, the WR on the break, and the ball as he accelerates.

GAME SPEED CATCHES



Contact Level

PURPOSE:

A WR catch circuit designed to improve catching ability in a variety of situations.

SETUP:

You'll need two coaches, a DB, and a WR. The WR will line up on the LOS, with one coach 5 yards in front of him, and the other 5 yards behind him. You will also place a cone 5 yards to his left, with a DB a couple yards back off the cone.

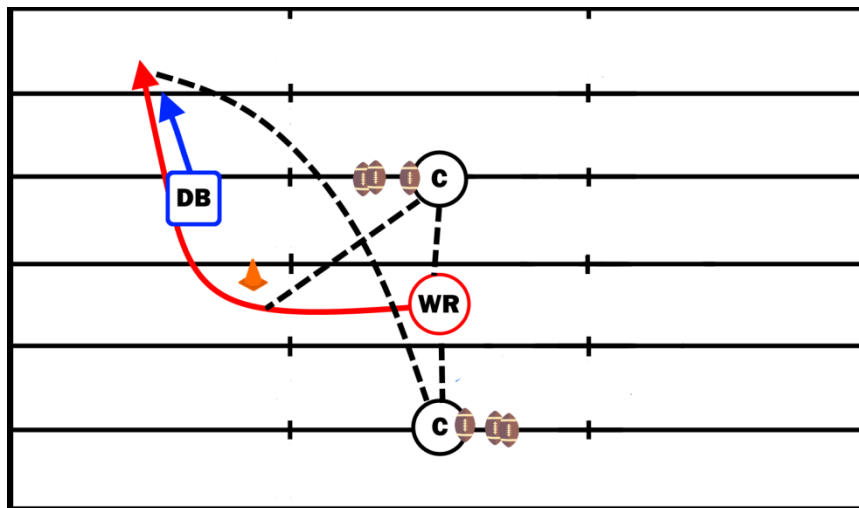

INSTRUCTIONS:

1. The drill begins with the WR facing the coach downfield.
2. He will throw the receiver a pass, who will catch it, and then immediately turn 180 degrees and make the next catch from the coach upfield.
3. After making that catch, the WR will sprint towards the cone, making a moving catch from the coach downfield.
4. Lastly, the WR will bend around the cone, sprint past the DB, and catch a deep pass from the coach up field to end the drill.

COACH'S CORNER

- This drill should be run crisply and quickly – the passes should be thrown before the WR has set and turned to catch them, giving them a chance to work on locating the pass and making the catch.

MIRROR STALK BLOCK

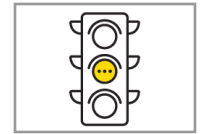

Contact Level

PURPOSE:

To teach players how to track and block defenders.

SETUP:

Begin by putting four cones down, 5 yards apart with one pair 3 yards behind the other. One player will step up to each side of the box.

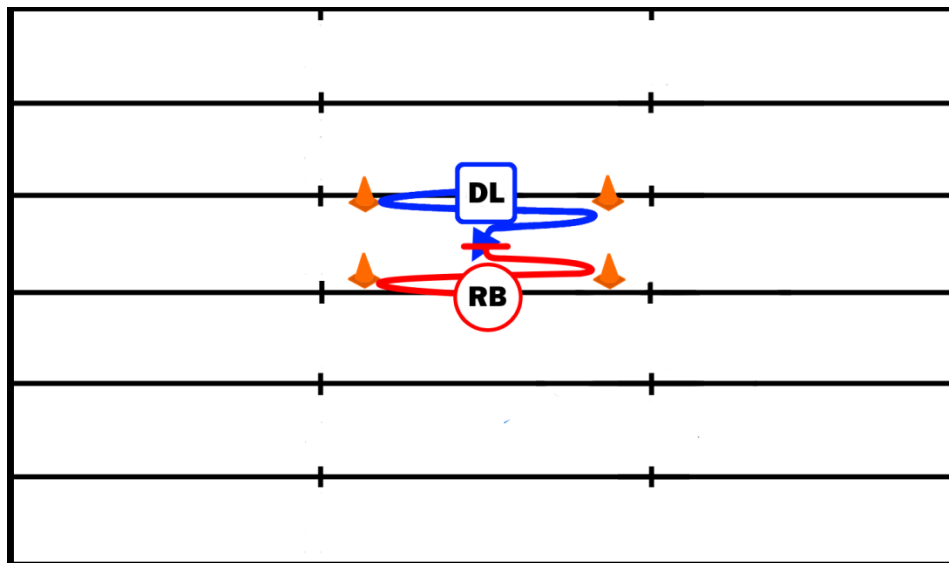

INSTRUCTIONS:

1. The blocker will follow the defender as the defender moves back and forth within the cone area.
2. The coach will then signal, and the defender will begin to attempt to move past the blocker – at around 50-75%.
3. The defender will use a punch technique, keeping two hands on the defender and preventing them from getting behind them.

COACH'S CORNER

- As players get more comfortable with the drill, you can increase the intensity, but remember this drill is designed to work on blocking techniques, not block shedding.
- Make sure the blocker does not cross his feet, staying square and in a low athletic stance for the entirety of the drill.



GAME PREP



PURPOSE:

To teach players how to read and react to the defense to find open seams in the defense.

SETUP:

This drill can be done a variety ways, from 3 on 3 to 7 on 7 and everything in between. Other than offensive and defensive players, all you'll need is a football.

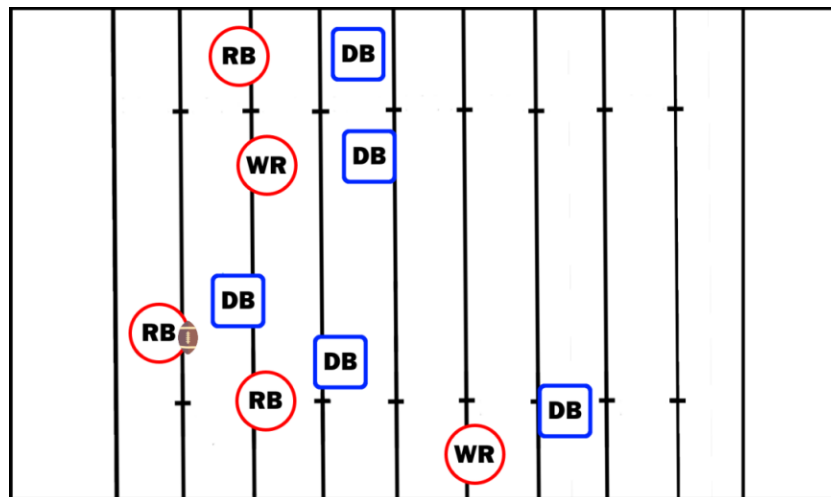

INSTRUCTIONS:

1. This is Ultimate Frisbee, with a football. Players are attempting to get to the end zone, but they are only allowed to take a maximum of 2 steps after catching the ball, and can only hold it for 10 seconds.
2. The ball can be passed in any direction, and offensive players can go anywhere they want on the field. The only rule defensively is that defenders cannot come closer than an arms length from the football.
3. If the offense makes it to the end zone, they get 7 points, and offense to defense flips going down the other way.

COACH'S CORNER

- Make it clear to players that this drill is not a race. The focus is on warming up and running with control and pace.

3 ON 3 PASSING



Contact Level

PURPOSE:

To give DBs and WRs a chance to work on passing and defending against zone coverage.

SETUP:

Have an offensive team (2 WRs, 1 QB) and a defensive team (2 CBs, 1 DB/LB) line up on the field. The QB will need a football as well. The WRs and CBs will be in their normal alignment, with the DB 10 yards deep over the middle.

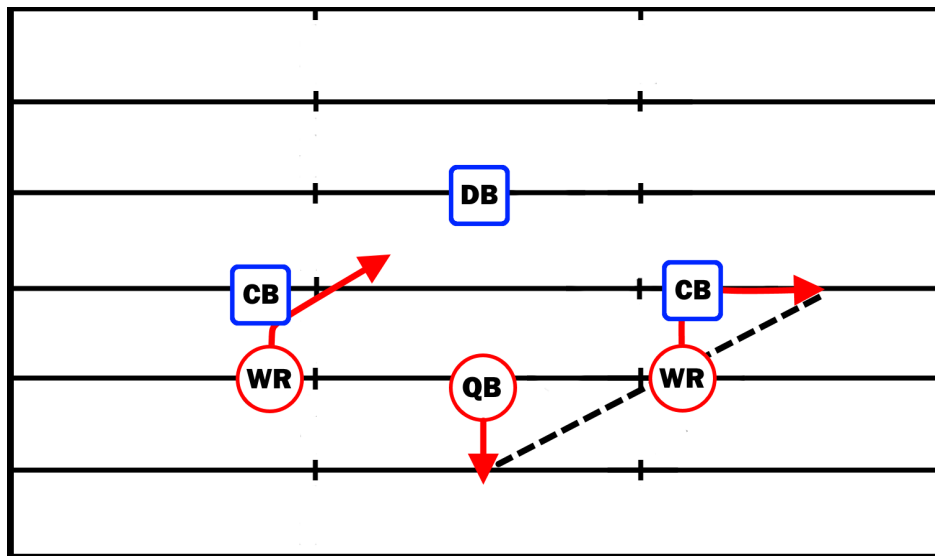

INSTRUCTIONS:

1. Before the play, tell the WRs and QB what play they are running.
2. The QB will then snap the ball, make a read, and attempt to hit an open WR.
3. Cycle in a new 3 after each play.

COACH'S CORNER

- This can be a really fun competitive team drill. Do Winners Stay On, and see if you can crown a 3 on 3 champion squad on your team!
- Be sure to work on a variety of routes, and keep contact to a minimum – we are working on route running and coverage here, not tackling.

MAN PRESS DRILL

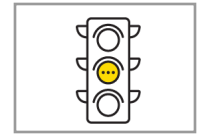

Contact Level

PURPOSE:

To give WRs and DBs a chance to get reps in a 1 on 1 game-like coverage situation.

SETUP:

Have players pair off by size and speed. The first pair will step up, with the DB up in press coverage on the WR. A coach or passer will stand 10 yards to the right.

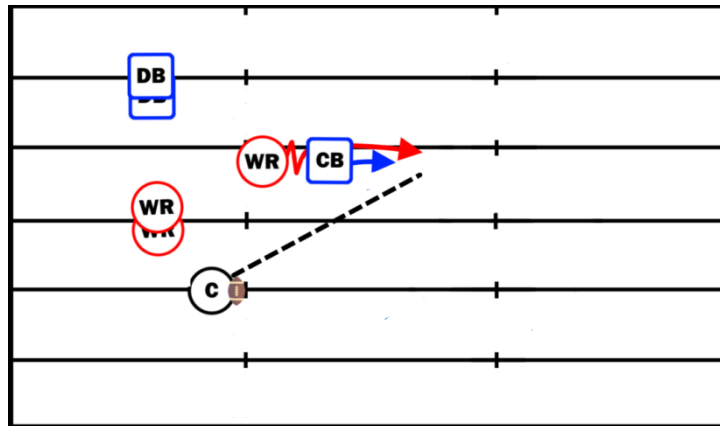

INSTRUCTIONS:

1. On the coach's snap, the DB will attempt to jam the WR, and the WR will attempt to beat the press.

COACH'S CORNER

- Make sure to vary your WRs routes so that they get a chance to work on a variety of ways in which they can beat man press.
- The goal of the DB is to disrupt the timing of the route. On the snap, he should immediately hit the WR with a hand strike to the chest to get him off-balance.
- As a counter-point, WRs should have their hands up and ready at the chest level, not down at their hips. This will allow them to engage in hand combat with the DB to free themselves more efficiently. This is why it's a good idea to work all of your players through trench drills as well, as the principles that make you effective as a lineman can be just as effective for skill players as well.
- Begin by working the DB with an inside shade, but much like how you need to vary the WR routes, the DBs need to get practice working outside shades as well.

TEAM PLAY REVIEW



Intermediate

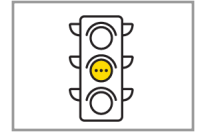

Contact Level

PURPOSE:

To teach, run, and perfect your favorite plays.

SETUP:

You will want a full lineup on both sides of the LOS.

PLAY CALLING CHART			
MONEY PLAY 1	MONEY PLAY 2	RUN PLAYS	ZONE
		Power Counter Sweep Dive Option	Cover 2 Cover 3 Cover 4 Cover 6
		SHORT PASS	
		Drive HB Angle Stick Scat	Nickel Blitz Cover 0 Cover 1
		SPECIALS	
		Punt Fake - FB Dive Punt Fake - P Pass	

INSTRUCTIONS:

1. Have the offense huddle up, give your QB the play, and have him call the play to the huddle.
2. The offense will then break to the LOS and run the play.
3. Keep a close eye on all players, and make sure to they are running the play exactly as designed.
4. Bring the offense back to the huddle, and call another play.

COACH'S CORNER

- Alternate working on both offense and defense, with the other side of the ball running at 50% to give their teammates a chance to focus on technique and execution.
- Remember – Quality over Quantity. Its more important to run a few plays very well than a bunch of plays decently.



PRACTICE PLANS

60 MINUTE SKILL WORK PRACTICE

Required: 2 Coaches, Footballs, Cones

Warmup: 10 Mins (Full Team)

Quick Feet Drill - 5 mins

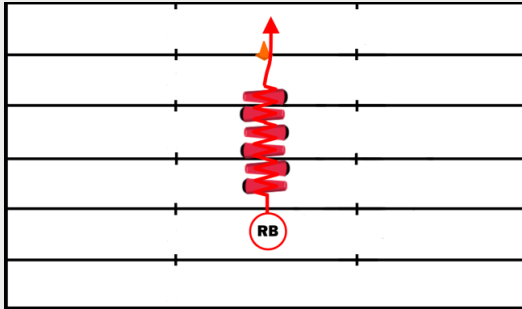

Side to Side - 5 mins

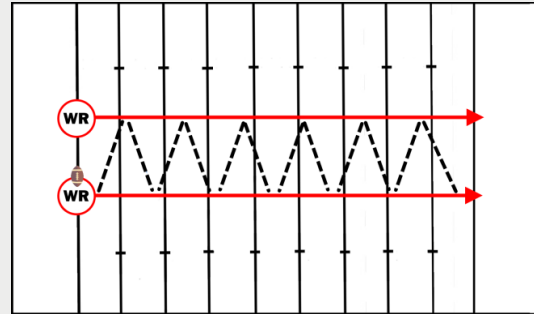

Station Block 1:

30 Mins (Split Team Into 3 Groups and Rotate Through Each Drill For 10 Mins)

Goal Line Drill - 10 mins

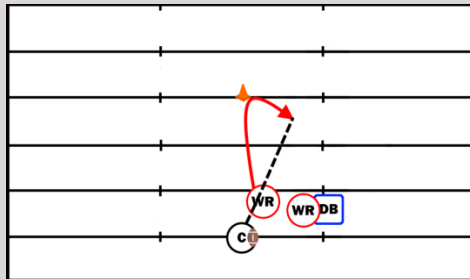

Read & Go Drill - 10 mins

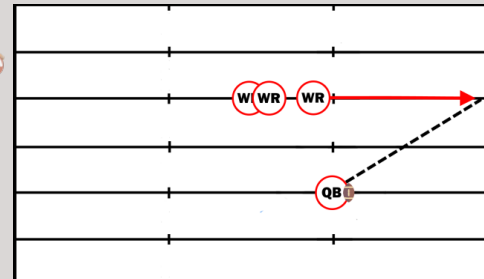

Clockwork Drill - 10 mins

Game Preparation:

20 Mins (Full Team)

Game Speed Catches - 10 mins

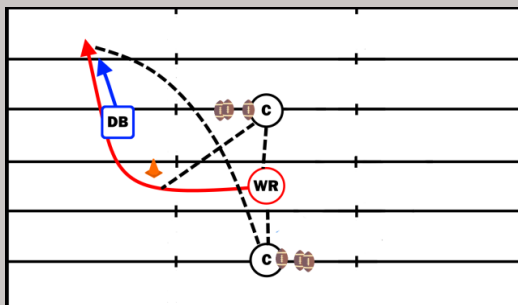

3 on 3 Passing - 10 mins

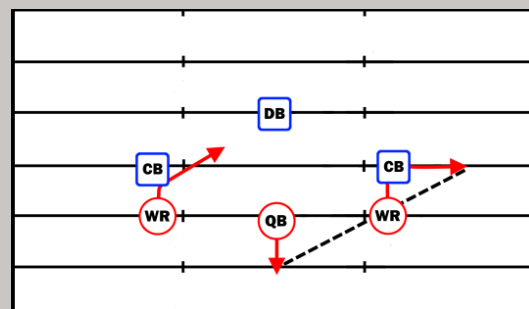

90 MINUTE SKILL WORK PRACTICE

Required: 3 Coaches, Footballs, Cones

Quick Feet Drill - 5 mins

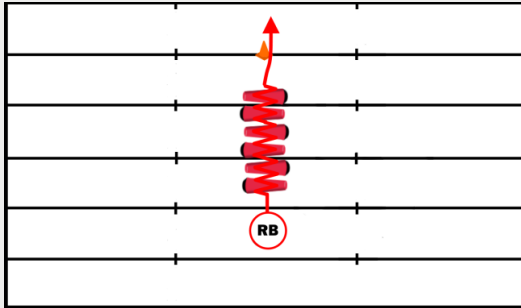

Side to Side - 5 mins

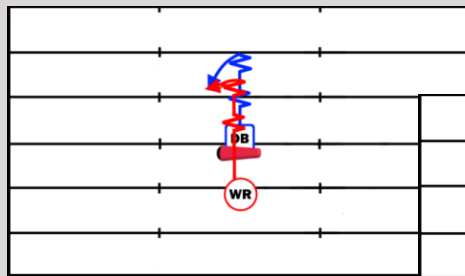
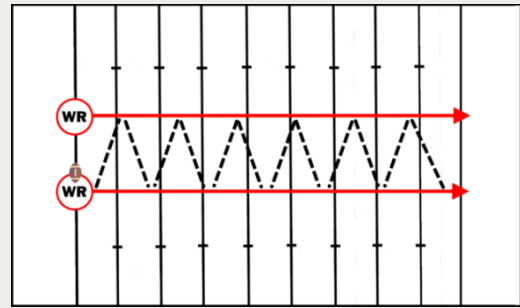

Footfire Drill - 10 mins

Match Hips - 10 mins

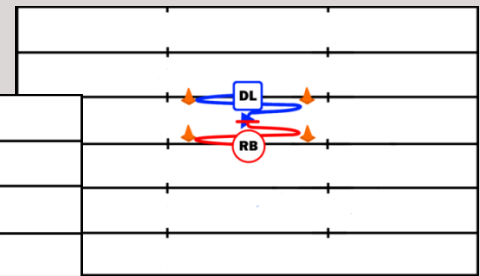

Mirror Stalk and Block - 10 mins

Ultimate Football - 15 mins

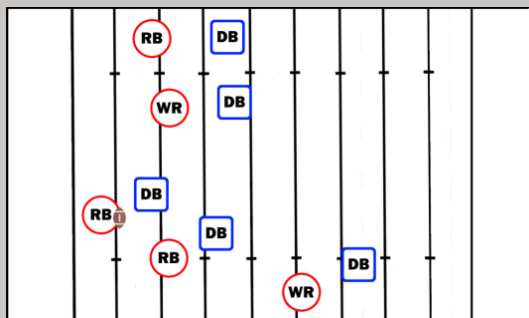

Man Press Drill - 15 mins

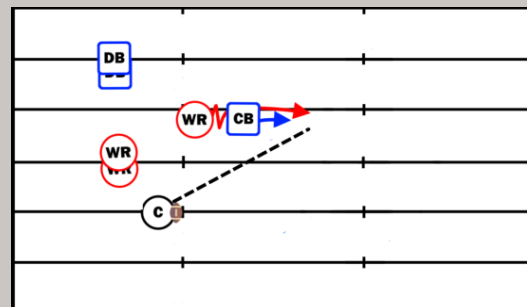

Run Play Review - 10 Mins

Practice your offensive plays at half speed against a dummy defense. Then full speed against a "Control" defense.

90 MINUTE SKILL WORK PRACTICE

Required: 2 Coaches, Footballs, Cones

Breakdown Plant & Drive - 5 mins

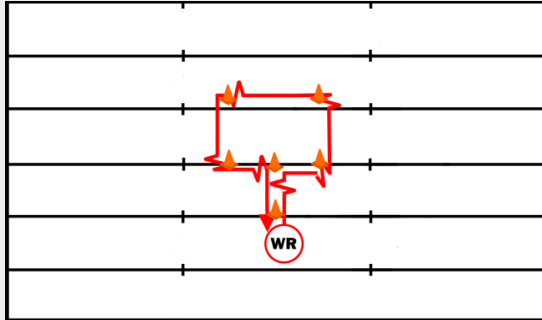

Backpedal Shuffle Break on Ball - 5 mins

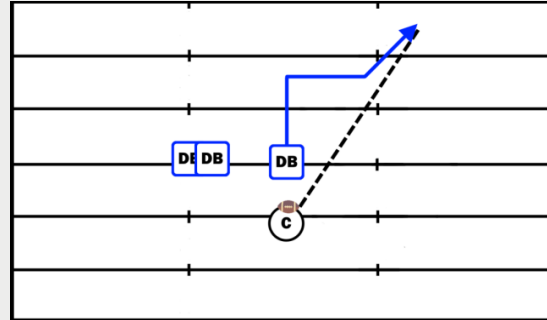

Station Block 1:

40 Mins (Split Team Into Two Groups and Rotate Through Each Drill For 10 Mins)

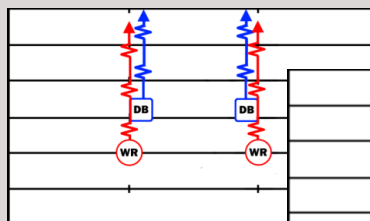

Match Hips Drill
- 10 mins

DB Zone Break
- 10 mins

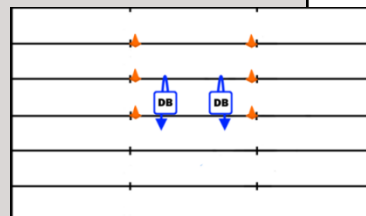
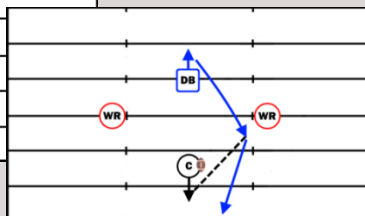

Cone Plant Reaction Drill
- 10 mins

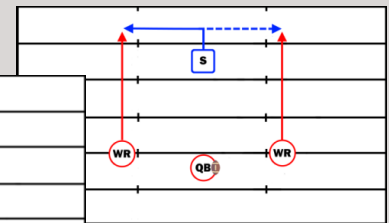

Stretch Break Drill
- 10 mins

Game Preparation: 15 Mins (Full Team)

Man Press Drill

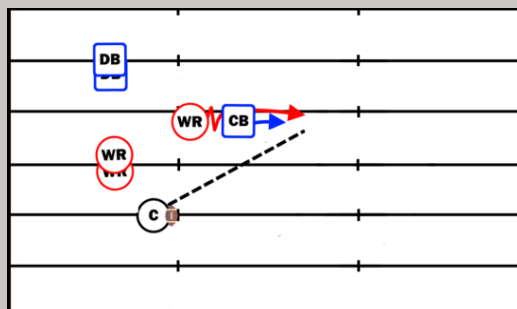

Run Play Review - 15 Mins

Practice your offensive plays at half speed against a dummy defense. Then full speed against a "Control" defense.

120 MINUTE SKILL WORK PRACTICE

Required: 3 Coaches, Footballs, Stand Up Dummy

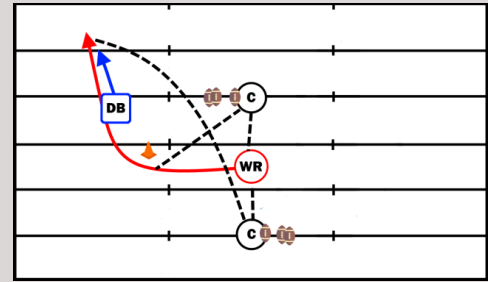
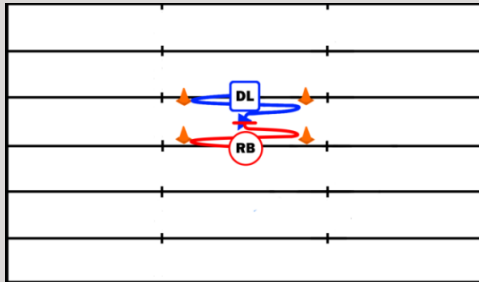
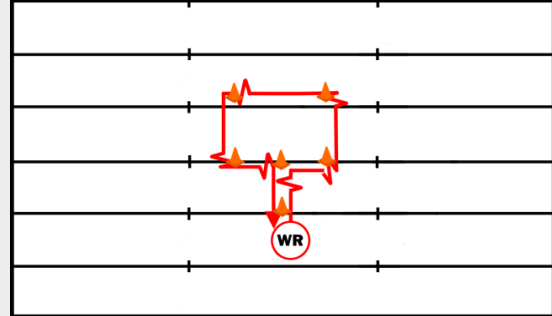
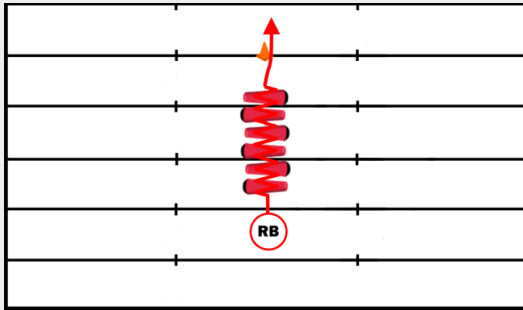

Mirror Stalk and Block Drill
- 10 mins

Clockwork Drill
- 10 mins

Game Speed Catches
- 10 mins

Ultimate Football - 15 mins

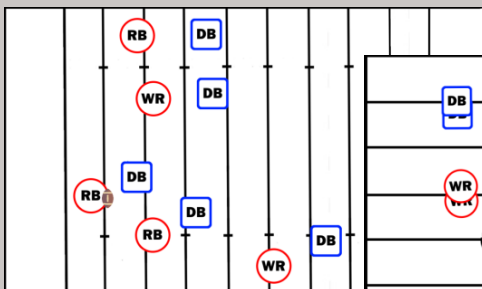

Man Press Drill
- 15 mins

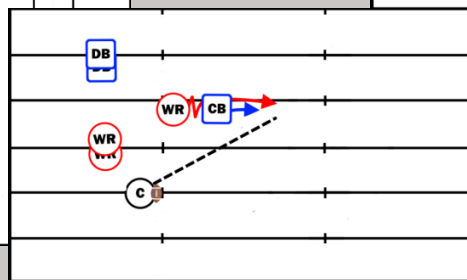

3 on 3 Passing - 15 mins

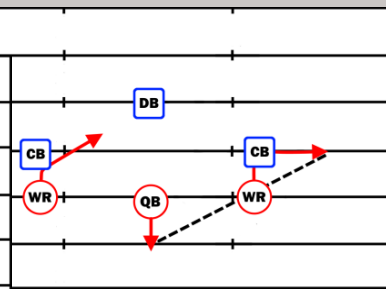

Run Play Review - 20 Mins

Practice your offensive plays at half speed against a dummy defense. Then full speed against a "Control" defense.